

INDUSTRIAL PUMPS & RAMS

NEW





INDUSTRIAL

SINGLE ACTING CYLINDERS

Capacity 5-95 TON

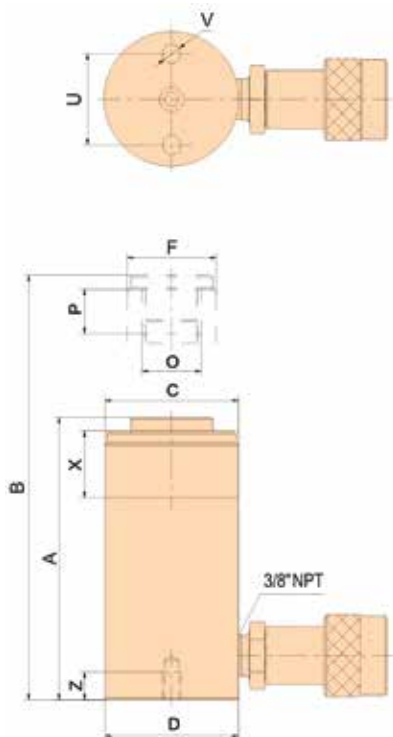

- Complies with ASME B-30.1
- High strength alloy steel for safety and durability
- Inside cylinder treated to enhance durability
- Features collar threads, plunger threads and base mounting holes for optional fixture attachments
- Heavy duty plunger spring return
- High quality 3/8"-18 NPT quick coupling
- Baked enamel finish for increased corrosion resistance

PRODUCT NO.	MODEL NO.	Cylinder Capacity @ 700 Bar (10,000 PSI)	Stroke	Cylinder Effective Area	Oil Capacity
		Metric Ton (US Ton)	In	In ²	In ³
033001	SACS50	5 (5.5)	0.63	1.10	0.70
033005	SACS55	5 (5.5)	5.00	1.10	5.50
033010	SACS102	10 (11)	2.13	2.25	4.78
033011	SACS104	10 (11)	4.13	2.25	9.29
033012	SACS106	10 (11)	6.14	2.25	13.80
033013	SACS108	10 (11)	7.99	2.25	17.96
033014	SACS1010	10 (11)	10.12	2.25	22.73
033035	SACS252	25 (27.5)	1.97	5.15	10.13
033036	SACS254	25 (27.5)	4.02	5.15	20.66
033037	SACS256	25 (27.5)	6.22	5.15	32.00
033038	SACS258	25 (27.5)	8.27	5.15	42.53
033039	SACS2510	25 (27.5)	10.28	5.15	52.86
033050	SACS506	50 (55)	6.26	10.99	68.77
033060	SACS1006	95 (104.7)	6.61	20.62	136.30





INDUSTRIAL

SINGLE ACTING CYLINDERS

Capacity 5-95 TON

Collapsed Height	Extended Height	Collar Thread	Collar Thread Length	Outside Diameter	Piston Rod Diameter	Piston Internal Thread	Piston Thread Length	Base Fixturing Holes			Product Weight
								Bolt Circle U	Thread V	Thread Depth Z	
A	B	C	X	D	F	O	P	U	V	Z	lb / kg
In	In	In	In	In	In		In	In	In	In	
1.65	2.28	-	-	2.32 x 1.65	0.98	-	-	1.10	0.22	-	1.8 / 0.8
8.46	13.46	1-1/2 - 16	1.10	1.50	0.98	3/4 - 16UNF	0.63	0.98	1/4 - 20UNC	0.55	3.7 / 1.7
4.76	6.89	2-1/4 - 14	1.02	2.25	1.50	1 - 8UNC	0.75	1.54	5/16 - 18UNC	0.47	3.7 / 1.7
6.73	10.87	2-1/4 - 14	1.02	2.25	1.50	1 - 8UNC	0.75	1.54	5/16 - 18UNC	0.47	6.4 / 3
9.72	15.87	2-1/4 - 14	1.02	2.25	1.50	1 - 8UNC	0.75	1.54	5/16 - 18UNC	0.47	9.0 / 4.1
11.73	19.72	2-1/4 - 14	1.02	2.25	1.50	1 - 8UNC	0.75	1.54	5/16 - 18UNC	0.47	10.8 / 4.9
13.74	23.86	2-1/4 - 14	1.02	2.25	1.50	1 - 8UNC	0.75	1.54	5/16 - 18UNC	0.47	12.3 / 5.6
6.50	8.46	3-5/16 - 12	2.13	3.39	2.24	1-1/2 - 16UN	1.02	2.28	1/2 - 13UNC	0.75	13.6 / 6.2
8.46	12.48	3-5/16 - 12	2.13	3.39	2.24	1-1/2 - 16UN	1.02	2.28	1/2 - 13UNC	0.75	17.6 / 8
10.75	16.97	3-5/16 - 12	2.13	3.39	2.24	1-1/2 - 16UN	1.02	2.28	1/2 - 13UNC	0.75	22.7 / 10.3
12.72	20.98	3-5/16 - 12	2.13	3.39	2.24	1-1/2 - 16UN	1.02	2.28	1/2 - 13UNC	0.75	26.6 / 12.1
14.72	25.00	3-5/16 - 12	2.13	3.39	2.24	1-1/2 - 16UN	1.02	2.28	1/2 - 13UNC	0.75	31.0 / 14.1
11.10	17.36	5 - 12	2.17	5.00	3.15	-	-	3.74	1/2 - 13UNC	0.75	48.8 / 22.1
14.06	20.67	6-7/8 - 12	1.73	6.97	4.13	-	-	5.47	3/4 - 10UNC	0.98	131.3 / 159.6

1. Guide ring eliminates over travel, and provides support to reduce wear from off-centre loads.
2. Heavy duty wiper ring keeps dust and debris out of cylinder body, improving performance and service life.
3. Bearing ring provides additional support to reduce wear from off-centre loads.
4. All-steel body with baked enamel finish for durability.
5. Hardened and chromed piston increases durability and reduces wear.
6. Secondary gasket and industrial seal ring assembly prevents costly leaks.
7. Standard coupler on all cylinders provided with heavy duty dust cover.
8. High strength return spring.

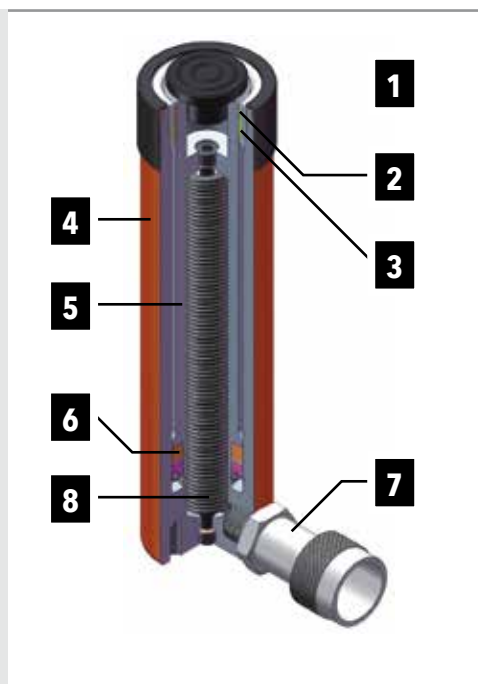



LOW HEIGHT SINGLE ACTING CYLINDERS

CAPACITY 5-50 TON



- For use in confined spaces
- Complies with ASME B-30.1
- High strength alloy steel for durability
- Mounting holes for fixture attachment
- Heavy duty plunger return springs
- High quality 3/8"-18NPT quick coupling
- Grooved plunger end with threaded hole for mounting tilt saddles
- Baked enamel finish for increased corrosion resistance



INDUSTRIAL

**LOW HEIGHT
SINGLE ACTING CYLINDERS**

Capacity 5-50 TON

1. Steel guide ring eliminates over travel and withstands full dead-end load, it also provides support to reduce wear from off-centre loads.
2. Hardened and chromed piston increases durability and reduces wear.
3. All-steel body with baked enamel finish for durability.
4. High strength return spring.
5. Secondary gasket and industrial seal ring assembly prevents costly leaks.
6. Standard coupler on all cylinders provided with heavy duty dust cover.

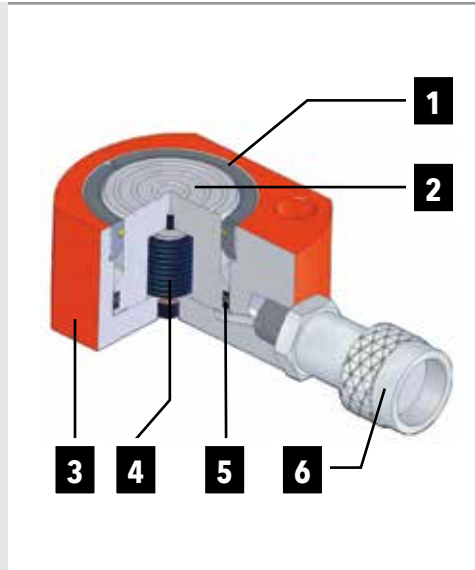

PROD NO.	MOD NO.	Cylinder Capacity @ 700 Bar (10,000 PSI) Metric Ton (US Ton)	Stroke In	Cylinder Effective Area In ²	Oil Capacity In ³	Collapsed Height	Extended Height	Outside Diameter In	Piston Rod Diameter In	Top Dimensions				Product Weight lb / kg
						A In	B In			D In	F In	M In	L In	
033061	SACL50	5 (5.5)	0.24	1.10	0.26	1.30	1.54	2.32 x 1.65	0.98	0.91	0.83	0.22	1.12	1.30 / 0.6
033063	SACL100	10 (11)	0.39	2.25	0.88	1.65	2.09	3.27 x 2.20	1.50	1.34	1.10	0.28	1.44	3.30 / 1.5
033065	SACL200	20 (22)	0.43	4.39	1.90	2.01	2.44	3.98 x 3.00	2.01	1.57	1.57	0.39	1.94	5.90 / 2.7
033070	SACL300	30 (33)	0.51	6.48	3.31	2.30	2.80	4.61 x 3.74	2.60	1.77	1.89	0.39	2.05	9.50 / 4.3
033074	SACL500	50 (55)	0.63	9.86	6.21	2.64	3.27	5.51 x 4.49	2.76	2.13	2.24	0.43	2.62	14.70 / 6.7

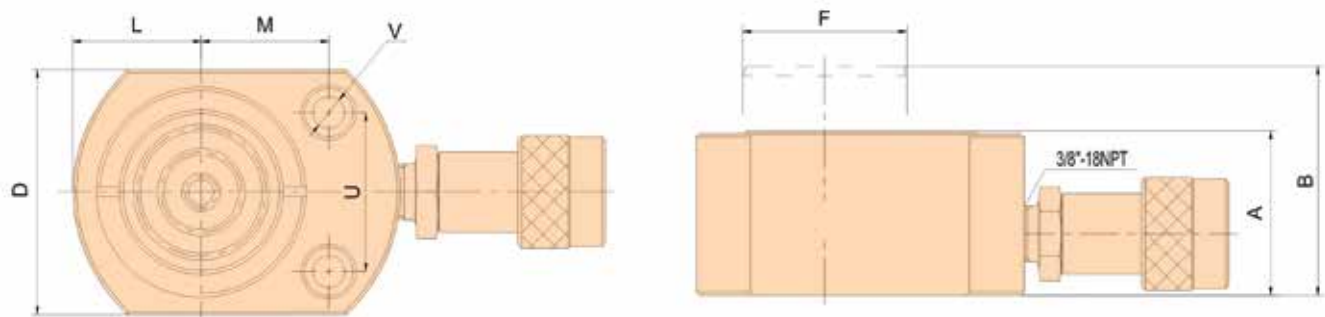



INDUSTRIAL

**HOLLOW CENTRE
SINGLE ACTING CYLINDERS**

Capacity 20-30 TON

- Hollow plunger design allows for both push and pull forces
- Complies with ASME B-30.1
- High strength alloy steel for durability and added safety
- Single acting spring return
- High quality 3/8"-18NPT quick couplings
- Collar and plunger threads for fixture attachment
- Baked enamel finish for corrosion resistance

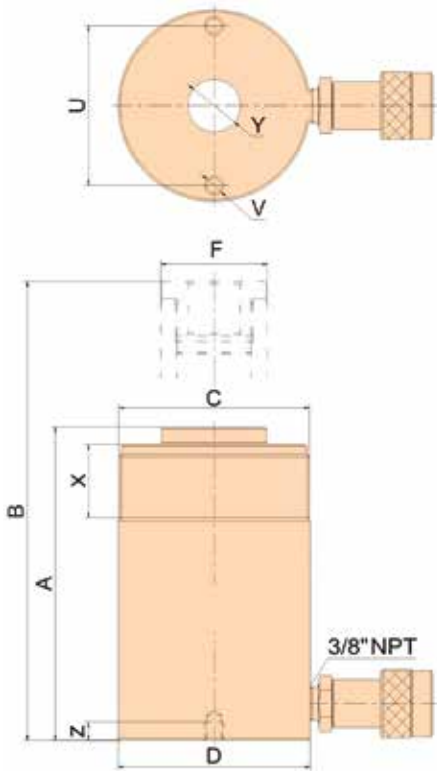

PROD NO.	MOD NO.	Cylinder Capacity @ 700 Bar (10,000 PSI)	Stroke	Cylinder Effective Area	Oil Capacity
		Metric Ton (US Ton)	In	In ²	In ³
033076	SACH202	20 (22)	1.93	5.08	9.80
033077	SACH206	20 (22)	6.10	5.08	31.01
033078	SACH302	30 (33)	2.52	7.39	18.62
033079	SACH306	30 (33)	6.10	7.39	45.10



INDUSTRIAL

**HOLLOW CENTRE
SINGLE ACTING CYLINDERS**

Capacity 20-30 TON

1. Steel guide ring eliminates over travel and withstands full dead-end load, it also provides support to reduce wear from off-centre loads.
2. Bearing ring provides additional support to reduce wear from off-centre loads.
3. Hardened and chromed piston increase durability and reduces wear.
4. High strength return spring.
5. All steel body with baked enamel finish for durability.
6. Industrial bearing ring provides additional support to reduce wear from off-centre loads.
7. Industrial seal ring assembly prevent costly leaks.
8. Standard coupler on all cylinders provided with heavy duty dust cover.

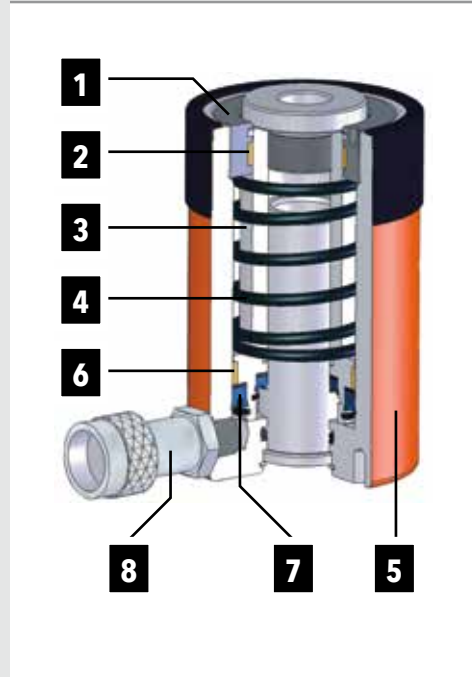

Collapsed Height A	Extended Height B	Collar Thread C	Collar Thread Length X	Outside Diameter D	Piston Rod Diameter F	Base Fixturing Holes			Centre Hole Diameter Y	Product Weight
						Bolt Circle U	Thread V	Thread Depth Z		
In	In	In	In	In	In	In	In	In	In	lb / kg
6.38	8.31	3-7/8-12	1.50	3.90	2.17	3.25	3/8-16UNC	0.37	1.06	16.06 / 7.3
12.05	18.15	3-7/8-12	1.50	3.90	2.17	3.25	3/8-16UNC	0.37	1.06	29.48 / 13.4
7.01	9.53	4-1/2-12	1.65	4.53	2.56	3.63	3/8-16UNC	0.55	1.31	23.10 / 10.45
12.99	19.09	4-1/2-12	1.65	4.53	2.56	3.63	3/8-16UNC	0.55	1.31	42.46 / 19.3



INDUSTRIAL

AIR/HYDRAULIC FOOT PUMPS

- Can be used with a variety of hydraulic cylinders, presses or other hydraulic equipment
- Provides up to 10,000 PSI of hydraulic pressure (0.6 - 1.0 Mpa)
- Air exhaust muffler for quiet operation
- Internal load limiting device provides overload protection
- Air input port thread 1/4" NPT, Oil output 3/8"-18NPT
- Features both air and oil filters to reduce risk of damage from environmental contaminants

PRODUCT NO.	MODEL NO.	Pressure Rating	Air Source Pressure	Usable Oil Capacity	Flow		Dimensions			Reservoir Material	Control Method	Product Weight
					No Load	Load	L	W	H			
		PSI	PSI	IN ²	In ³ /Min		In	In	In			lb / kg
033125	AHP002	10,000	90-145	98	49.5	7.6	10.3	5.3	7.3	Aluminum alloy	Foot pedal	19 / 9
033126	AHP003	10,000	90-145	275	49.5	7.6	12.5	7	7.5	Steel	Foot pedal	28 / 13
033127	AHP004	10,000	90-145	442	49.5	7.6	11	8.8	10	Steel	Foot pedal	36 / 16

AIR/HYDRAULIC FOOT PUMP SELECTION

PROD NO.	MOD NO.	Stage	Flow (In ³)	Capacity (Tons)								
				5	10	15	25	30	50	75	100	150
				Required time (seconds) for cylinder to lift 1 inch								
033125	AHP002	Low Pressure	0.81	1.30	2.90	3.90	6.40	8.30	15.00	19.50		
		High Pressure	0.12	8.70	19.00	26.30	42.50	55.00	100.00	130.00		
033126	AHP003	Low Pressure	0.81	1.30	2.90	3.90	6.40	8.30	15.00	19.50	25.60	
		High Pressure	0.12	8.70	19.00	26.30	42.50	55.00	100.00	130.00	166.00	
033127	AHP004	Low Pressure	0.81	1.30	2.90	3.90	6.40	8.30	15.00	19.50	25.60	38.00
		High Pressure	0.12	8.70	19.00	26.30	42.50	55.00	100.00	130.00	166.00	252.50



INDUSTRIAL

SINGLE ACTING HAND PUMPS

- Single acting hand pumps made of high strength alloy steel; corrosion resistant and engineered for use in extreme environments
- Internal pressure relief valve for overload protection
- Compact design for storage and transportation
- Compatible with various cylinders and tools

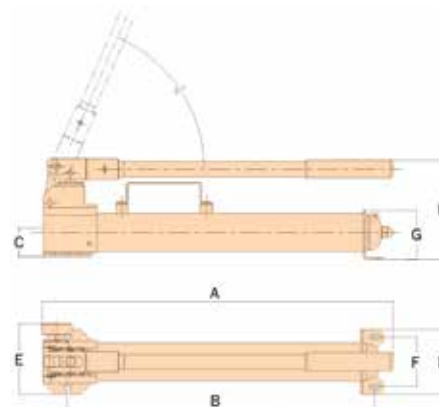
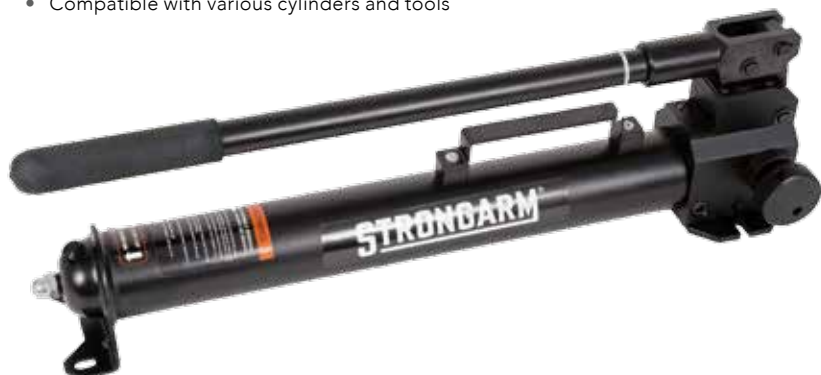

PRODUCT NO.	MODEL NO.	Speed	Usable Oil Volume	Pressure Rating		Oil Output Per Stroke		Handle Force	Oil Output Thread	Product Weight
				1st Stage	2nd Stage	1st Stage	2nd Stage			
			In ³	PSI	PSI	In ³	In ³	lb	In	lb / kg
033101	HPS55	Dual	55	360	10,000	2.038	0.201	108	3/8 - 18NPT	16.06 / 4.56
033102	HPS140	Dual	140	360	10,000	2.038	0.201	108	3/8 - 18NPT	22.22 / 10.08

HAND PUMP SELECTION CHART

PRODUCT NO.	MODEL NO.	Stage	Flow (In ³)	Capacity (Tons)						
				5	10	15	25	30	50	75
				Required strokes for cylinder to lift 1 inch						
033101	HPS55	1st Stage	2.038	1	2	2	3			
		2nd Stage	0.201	6	12	16	26			
033102	HPS140	1st Stage	2.038	1	2	2	3	4	6	8
		2nd Stage	0.201	6	12	16	26	31	55	81



INDUSTRIAL RUBBER HYDRAULIC HOSES



PRODUCT NO.	MODEL NO.	Hose Material	Internal Diameter	Working Pressure	Burst Pressure	Thread	Length
			In	PSI	PSI	In	Ft
033130	HPH8206	Rubber	1/4	10,000	20,000	3/8 - NPT	6
033131	HPH8210	Rubber	1/4	10,000	20,000	3/8 - NPT	10
033132	HPH8220	Rubber	1/4	10,000	20,000	3/8 - NPT	20
033137	HPH7306	Rubber	3/8	10,000	20,000	3/8 - NPT	6
033138	HPH7310	Rubber	3/8	10,000	20,000	3/8 - NPT	10
033139	HPH7320	Rubber	3/8	10,000	20,000	3/8 - NPT	20

QUICK COUPLERS

PRODUCT NO.	MODEL NO.	Max Pressure	Type	Thread	Coupler Type
		PSI		In	
033140	QC201MF				Male / Female
033141	QC201F	10,000	High flow	3/8 - 18NPT	Female
033142	QC201M				Male

HYDRAULIC VALVES

Manual Needle Valve 033165

- Needle valve, manually controls the speed of cylinder, can be used as a shut-off valve for temporary load holding

Manual Check Valve 033160

- Manually operated check valve used to hold load with single or double acting cylinder, manually opened to allow oil to flow back to oil reserve when cylinder retracts.



033165



033160



INDUSTRIAL PRESSURE GAUGES



PRODUCT NO.	MODEL NO.	Pressure Range		Thread	Gauge Diameter
		MPa	PSI	In	In
033150	HPG2510	0 - 100	0 - 15,000	1/4 - NPT	2.5
033151	HPG4010	0 - 100	0 - 15,000	1/2 - NPT	4

GAUGE ADAPTERS

PRODUCT NO.	MODEL NO.	Female Coupler Thread	Male Coupler Thread	Gauge Thread	A	B	C	D	E	F
		In	In	In	In	In	In	In	In	In
033152	GA001	3/8 - NPT	3/8 - NPT	1/2 - NPT	2.79	1.22	1/2 - NPT	3/8 - NPT	3/8 - NPT	1.25
033153	GA002	3/8 - NPT	3/8 - NPT	1/2 - NPT	6.1	1.37	1/2 - NPT	3/8 - NPT	3/8 - NPT	1.25
033154	GA003	3/8 - NPT	3/8 - NPT	1/4 - NPT	5.23	1.88	1/4 - NPT	3/8 - NPT	3/8 - NPT	1.25
033155	GA004	3/8 - NPT	1/4 - NPT	1/2 - NPT	4.37	1.37	1/2 - NPT	1/4 - NPT	3/8 - NPT	1.25
033156	GA005	3/8 - NPT	3/8 - NPT	1/4 - NPT	5.27	1.37	1/4 - NPT	3/8 - NPT	1/4 - NPT	1.25

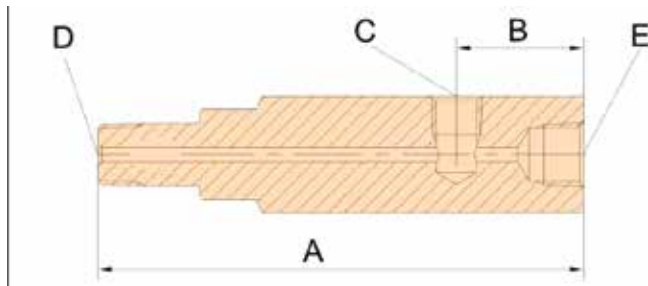

WARRANTY

ONE YEAR LIMITED WARRANTY

JET EQUIPMENT & TOOLS LTD. (JET®) makes every effort to ensure that STRONGARM branded products meet the highest quality and durability standards. All STRONGARM products are guaranteed to be free of defects in material and workmanship for a period of one year following the date of purchase. This warranty is extended to the original retail purchaser only.

If one of these products fail during its warranty period due to defective material or workmanship, it will be repaired or replaced at JET's discretion.

This warranty does not apply to any product showing signs of abuse, misuse, overloading, alteration, or improper maintenance. Normal wear and tear on moving parts or seals where applicable is specifically excluded from this warranty. To obtain repair or replacement, the defective product must be shipped, transportation charges prepaid, to the nearest authorized service depot with proof of purchase.

Repair or replacement is the exclusive remedy for defective equipment under this warranty. This Warranty is expressly in lieu of all other warranties, including the implied warranty of merchantability or any implied warranty of fitness for a particular application on this equipment.

JET shall not be liable for any consequential or incidental damages for breach of any expressed or implied warranty on this equipment.

WARNING

JACKS ARE FOR LIFTING VEHICLES ONLY. Support the vehicle with safety stands immediately after lifting.

DO NOT attempt to move the vehicle with the jack. Use only on a hard level surface.

Auxiliary / High Stands are for accessories only and are not designed or intended to support a vehicle. Transmission Jacks are for the removal, installation and transportation of transmissions and differentials. Transmission Jacks may be used with appropriate adapters manufactured specifically for the jack to handle other components, such as rear axle units and transfer cases, within the weight limitations specified. No alteration to any of the jacks or adapters shall be made. Do not overload. Do not extract or drain caustic or flammable products with any of our lubrication equipment. Only use the device for the purpose for which it has been designed. Follow safety instructions included with product for safe use.

JET reserves the right to change appearance and specifications at any time.